

## SP-600FVI

适用注塑机吨位：35~250ton  
Injection Press Range:35~250ton



### □机电一体化 Composite Type

控制箱、气动控制装置与机器本体合为一体。  
The control box, pneumatic control device and mechanical body are integrated.

### □上下取出行程可调节 Adjustable Vertical Stroke

通过调节阻挡的位置来调节上下取出行程。  
Adjustment of vertical stroke is possible by adjusting the stopper.

### □高速下降模式 High-speed Descent Mode

通过两个电磁阀控制下降时气缸的排气速度，以达到高速下降的效果，从而提高抓取速度、缩短抓取周期。  
The exhaust speed of cylinder is controlled by two valves to achieve the effect of high-speed descent, thus improving the speed and shortening the cycle.

### □直线轴承方式 Linear Bushing System

前后轴和上下轴采用直线轴承，可承受高速动作，确保低摩擦、高刚性和高精度。  
Linear bushing is used at straight guide of vertical and crosswise axes, for high durability and accuracy at high speed.

### □水口夹可旋转（选项） Runner Chuck Reversal (Option)

在进行成型品放置时，水口夹可旋转90°，更容易放开及有效防止成型品划伤。  
When placing the moulding part, the runner chuck can rotate 90°, which makes it easier to open and effectively prevent the moulding part from being scratched.

#### 机器型号 MODEL DESIGNATION

上下行程 600 / 800  
Crosswise Stroke  
**SP 600 FVI C**  
夹具部反转结构（选项）  
Chuck Part Reverse Structure (Option)

#### 机器型号 MODEL DESIGNATION

上下行程 600 / 800  
Crosswise Stroke  
**SP 600 FVI P**  
吸着确认单元（选项）  
Accuum Sensing Unit (Option)

# SP·FVI series

设计简洁且功能多样的流道专用旋转式取出机  
Simple and compact designed swing type sprue picker.

## 基本参数 COMMON SPECIFICATIONS

电源 Power Source	常用气压 Air Pressure	驱动方式 Drive System	气缸推力(气压:0.5MPa时) Air Cylinder Driving Force (Air Pressure at 0.5 MPa)	控制箱 Control Box
			最大可搬重量(含夹具重量) Max.Load, Incl. Chuck Weight	
AC200V±15% 50/60Hz(单相)	0.5 MPa	气缸 Air Cylinder	2 kg	STEC-S2

## 综合参数 GENERAL SPECIFICATIONS

机种 Model	行程(移动量) Stroke			电源设备容量 (VA) Electric Consumpition	本体重量(kg) (含控制箱) Net Weight (control box included)	空气消耗量 (Nℓ/周期) Air Consumption (Nℓ/cycle)
	上下(mm) Vertical	前后(mm) Crosswise	旋转 Swing			
SP-600FVI	600	75	50~90°	60	45	6.8
SP-800FVI	800	100				

## 标准功能 BUILT IN STANDARD FUNCTION

落下侧下降低速 Release Side Descent Slow Speed	机械臂在取出侧高速下降，达到缩短取出周期的目的。在落下侧低速下降，避免产品从夹具上脱落。 Arm descends at a high speed to accelerate the cycle on the product extract side. On the release side, arm descends at a low speed so that the product does not drop.
不良品排出回路 Defective Product Reject	与注塑机发出的不良品信号联动，进行不良品排出动作。 Defective products are ejected within mold interlocking with the defective product signal from IMM.
模内开放动作 Release Within Mold Motion	产品或水口从模具上剥离后，需要直接在模具内开放时使用此动作。 Used to release products or runners within mold after pulling them out of the mold.
注塑机联动/带单独切换开关 IMM Link/Independent Motion Select Switch	注塑机联动/单独切换时，前后臂在模外且未输出警报的情况下，解除互锁信号。 If crosswise arm is out of the mold and alarm is not output, interlock signal is canceled by selecting the independent mode of IMM link/independent motion select switch.
动作可能键 Enable Switch	手动操作时，按住动作可能键，然后按手动操作键来进行操作，以避免错误操作的发生。 In manual operation, press the manual operation key after pressing enable switch continuously to prevent the wrong operation.
显示历史警报履历 Alarm History Display	显示过去发生的警报No.信息。(最多10条) Alarm history data(Max 10 data)are displayed.

## 选项功能 POSSIBLE ADOPT

吸着确认单元 Vacuum Sensing Unit	0007-01	使用真空发生单元取出产品。 Products are extracted with vacuum generator.
剪切回路 (夹具内) Air Nipper Cut	0008-01	使用夹具内气剪剪切水口时, 需要此仕作。自动运转时, 在落下侧的产品开放位置处, 产品开放前进行此动作。 Used to take the cutting of direct gates or side gates with nipper in the chuck plate. When in automatic operation, cutting is made at product release position before the product release.
操作盒配线 (3M) Operation Box Wire(3M)	0006-04	操作盒配线可以延长至3米。 The wiring of operation box can be extended to 3 metres.



## 操作盒 CONTROLLER STEC-S2

### 3国语言切换 Three Language Exchange

操作盒的显示画面可切换3国语言 (日语、英语、汉语 (简体字))。Language switching between three languages can be used for display. Basically used languages are Japanese, English, and Chinese (Simplified).

### 换模记忆功能 Mold Change Memory

可记录30套模具的换模资料。Memory for up to 30 different molds is possible.

### 搭载USB端口 Carrying USB Ports

使用USB下载程序, 备份/上传换模数据。Use USB to download program, backup/upload the data of replacing mould.

### 控制·气动电源分离 Separation of control and power supply

紧急开关动作时保持供电, 缩短安全重启、复归的时间。Safe reboot and reduction of recovery time with emergent power source.

## 基本动作 MOTION PATTERN

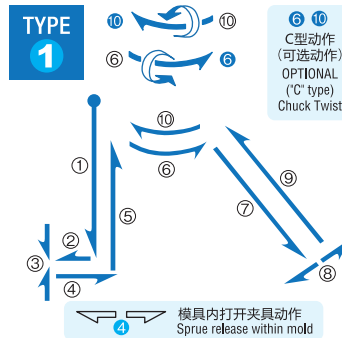

- |         |                           |
|---------|---------------------------|
| ① 下降    | Descent                   |
| ② 前进    | Crosswise advance         |
| ③ 夹取成型品 | Sprue grip                |
| ④ 后退    | Crosswise retreat         |
| ⑤ 放下成型品 | Sprue release within mold |
| ⑥ 上升    | Ascent                    |
| ⑦ 旋转    | Swing action              |
| ⑧ 反转夹具部 | Chuck twist               |
| ⑨ 下降    | Arm extend                |
| ⑩ 放下成型品 | Sprue release             |
| ⑪ 上升    | Arm retreat               |
| ⑫ 旋转复位  | Swing return              |
| ⑬ 反转夹具部 | Chuck twist return        |

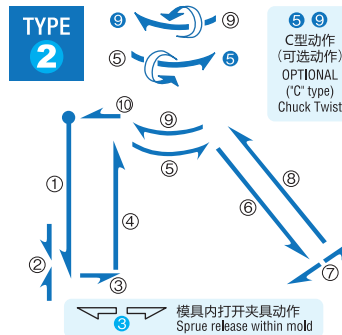

- |          |                           |
|----------|---------------------------|
| ① 下降     | Descent                   |
| ② 夹取成型品  | Sprue grip                |
| ③ 后退     | Crosswise retreat         |
| ④ 放下成型品  | Sprue release within mold |
| ⑤ 上升     | Ascent                    |
| ⑥ 旋转     | Swing action              |
| ⑦ 旋转夹具部  | Chuck twist               |
| ⑧ 下降     | Arm extend                |
| ⑨ 放下成型品  | Sprue release             |
| ⑩ 上升     | Arm retreat               |
| ⑪ 旋转复位   | Swing return              |
| ⑫ 反转夹具部  | Chuck twist return        |
| ⑬ 返回待机位置 | Crosswise advance         |

## 外形尺寸 OUTER DIMENSIONS

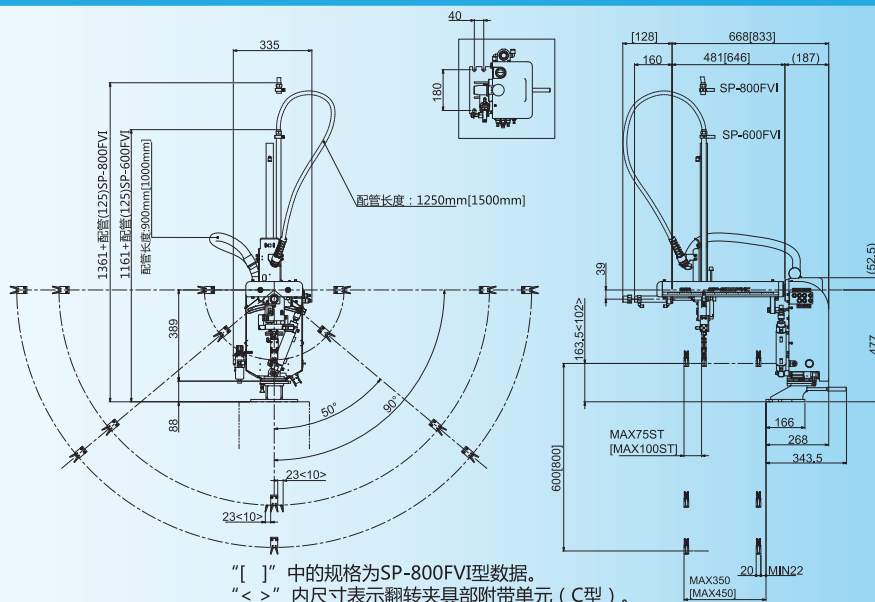

星精机械(上海)有限公司  
STAR SEIKI (SHANGHAI) CO., LTD.

### STAR中国区销售服务网络信息

<http://www.starseiki.cn>

#### 华东地区

- 大陆地区总部: 星精机械(上海)有限公司  
地址: 上海市徐汇区桂平路555号46栋208室  
☎ +86-021-5423 4571
- 苏州事务所 ☎ +86-0512-6805 8385
  - 厦门事务所 ☎ +86-0592-577 9994
  - 余姚事务所 ☎ +86-0574-6253 2721
  - 青岛分公司 ☎ +86-0532-5556 5517

#### 华北/东北地区

- 天津分公司 ☎ +86-022-5838 7675
- 大连分公司 ☎ +86-0411-8756 2176

#### 华南/西南/华中地区

- 深圳分公司 ☎ +86-0755-2962 2620
- 广州分公司 ☎ +86-020-3708 4205
- 武汉分公司 ☎ +86-027-8425 3500
- 重庆分公司 ☎ +86-023-6036 0877
- 成都分公司 ☎ +86-028-6549 5545
- 襄阳生产工厂 ☎ +86-0710-3311 813

#### 港澳台地区

- 香港公司 ☎ +852-2687 6745
- 中日龙股份有限公司(台北市) ☎ +886-2-2836 0039
- 台南营业所 ☎ +886-6-273 8985
- 台中营业所 ☎ +886-4-2463 1361

